



**DIPLOMATIC**  
HYDRAULICS

46 200/104 ED



## VP\*-W\*-MU

### HYDRO-PILOT OPERATED CHECK VALVES

#### SERIES 12

#### THREADED PORTS

**p** max 320 bar

**Q** max (see performance ratings table)

#### OPERATING PRINCIPLE

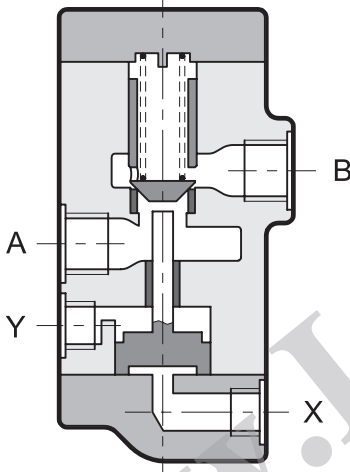

- VP\*-W\*-MU valves are check valves with hydraulic release, constructed in a version with threaded ports for mounting in-line on hydraulic lines.
- They incorporate the functions of a normal one-way check valve with the facility, by means of external piloting, to release the poppet and allow the oil to pass also in the direction opposite to the free flow, from B to A.
- In rest conditions, the valve poppet, which is a cone on edge seal type, is kept closed by a spring with fixed setting. When piloting pressure is sent to port X, the release piston is operated, thus opening the main poppet and allowing the free flow from B to A.
- The drainage port Y isolates the front face of the control piston from chamber A.
- They are available in two sizes for flow rates up to 100 l/min and with different cracking pressures in the A to B free flow direction.

#### PERFORMANCE RATINGS (working with mineral oil of viscosity of 36 cSt at 50°C)

		VP 3	VP 5
Maximum operating pressure	bar	320	320
Maximum flow rate	l/min	50	100
Piloting ratio between release piston and sealed chamber areas	VP*-W-MU	3,4 : 1	2,7 : 1
Piloting ratio with decompression device	VP*-W/P-MU	12 : 1	14 : 1
Port dimension	BSP	3/8"	3/4"
Ambient temperature range	°C	-20 ÷ +50	
Fluid temperature range	°C	-20 ÷ +80	
Fluid viscosity range	cSt	10 ÷ 400	
Recommended viscosity	cSt	25	
Fluid contamination degree	According to NAS 1638 class 10		
Mass	kg	3,1	4,4

#### HYDRAULIC SYMBOL

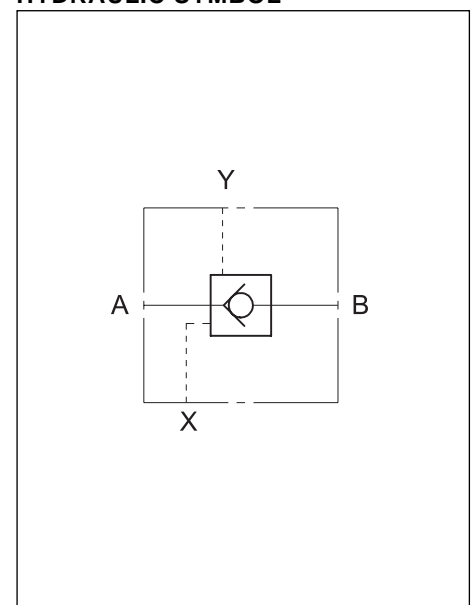



## 1 - IDENTIFICATION CODE

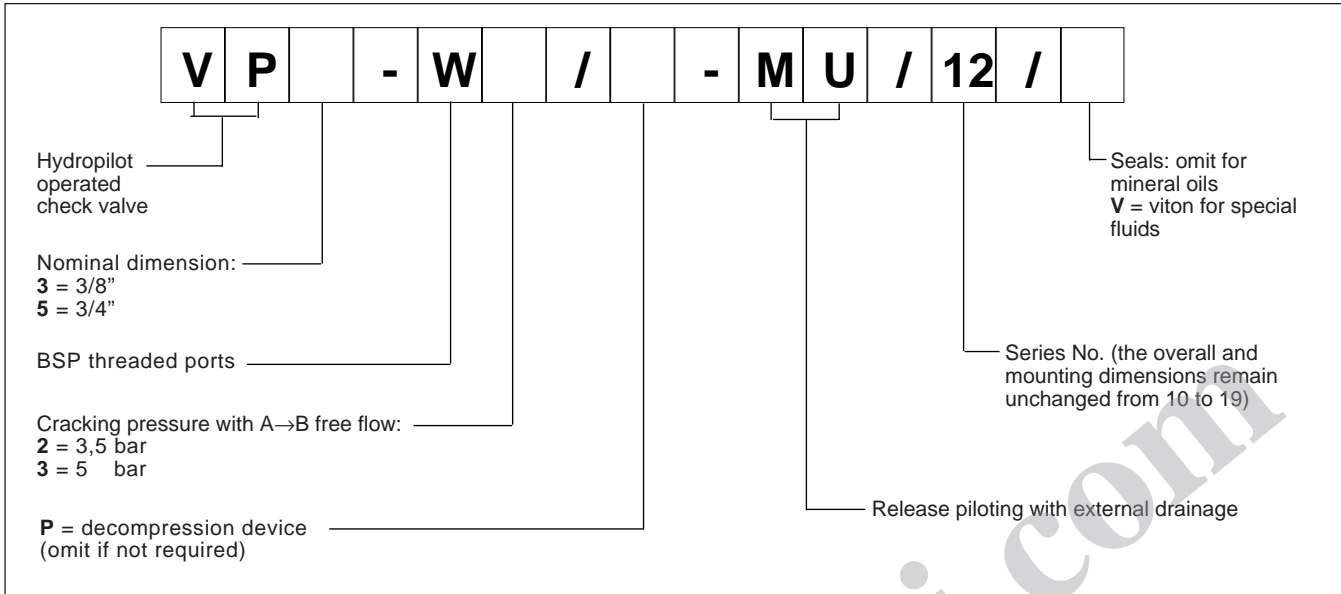

## 2 - CHARACTERISTIC CURVES (values obtained with viscosity 36 cSt at 50°C)

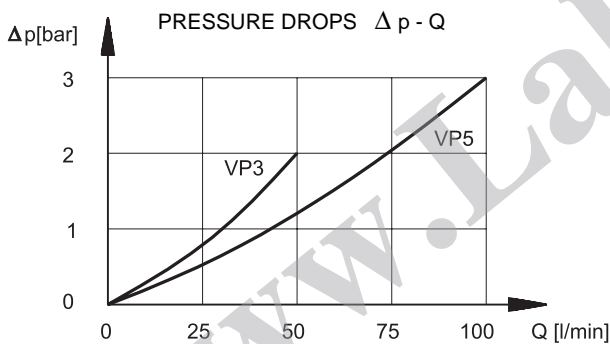

**Note:** The curves shown in the graph refer to B→A and A→B flow with valve released hydraulically.  
For A→B flow, with valve not released hydraulically, add the cracking pressure to the values shown.

## 3 - HYDRAULIC FLUIDS

Use mineral oil-based hydraulic fluids, with the addition of suitable anti-frothing and anti-oxidising agents.  
For the use of other fluid types (water glycol, phosphate esters and others), please consult our technical department.



**4 - VP 3-W\*-MU OVERALL AND MOUNTING DIMENSIONS**

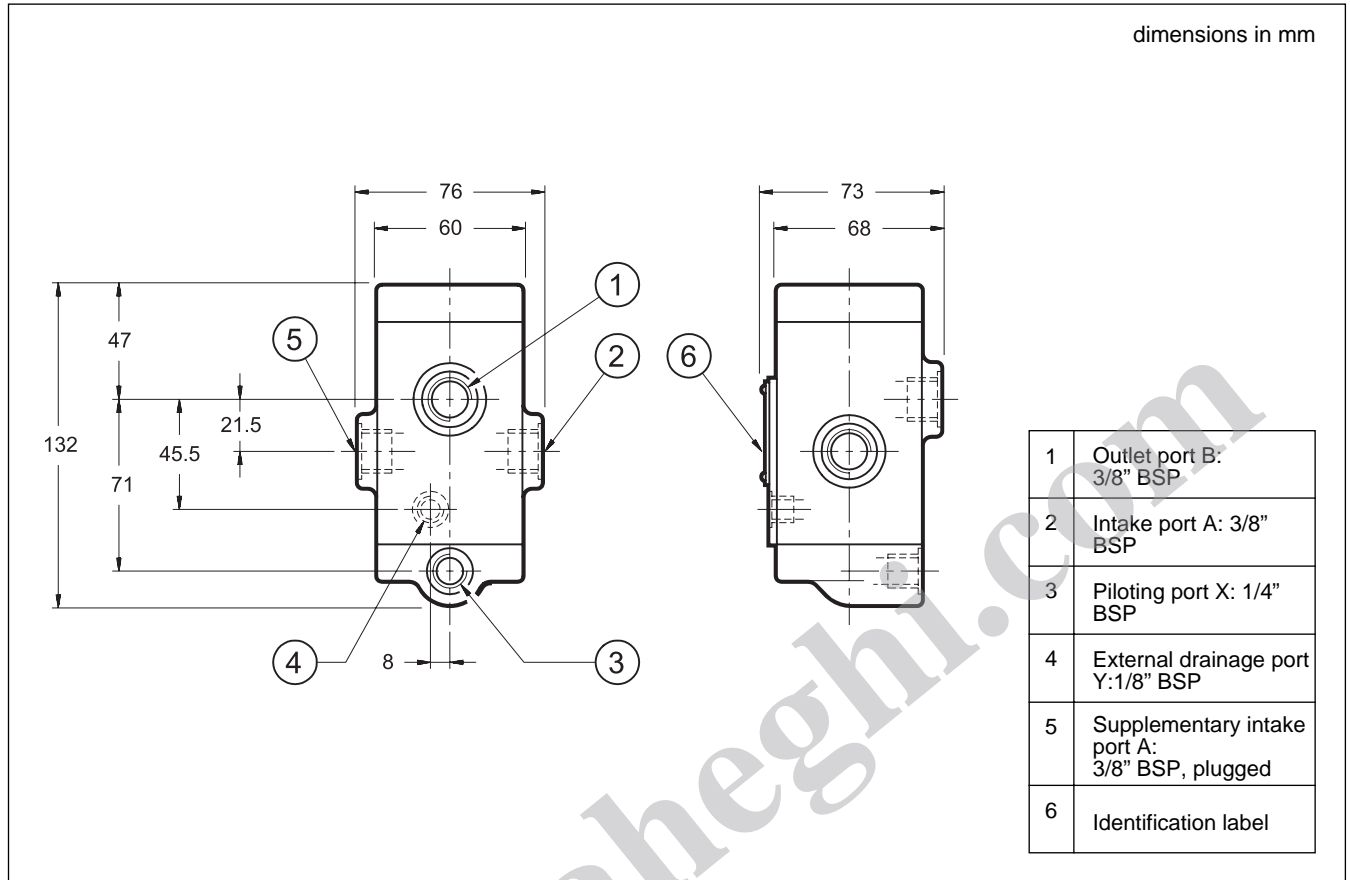

**5 - VP 5-W\*-MU OVERALL AND MOUNTING DIMENSIONS**

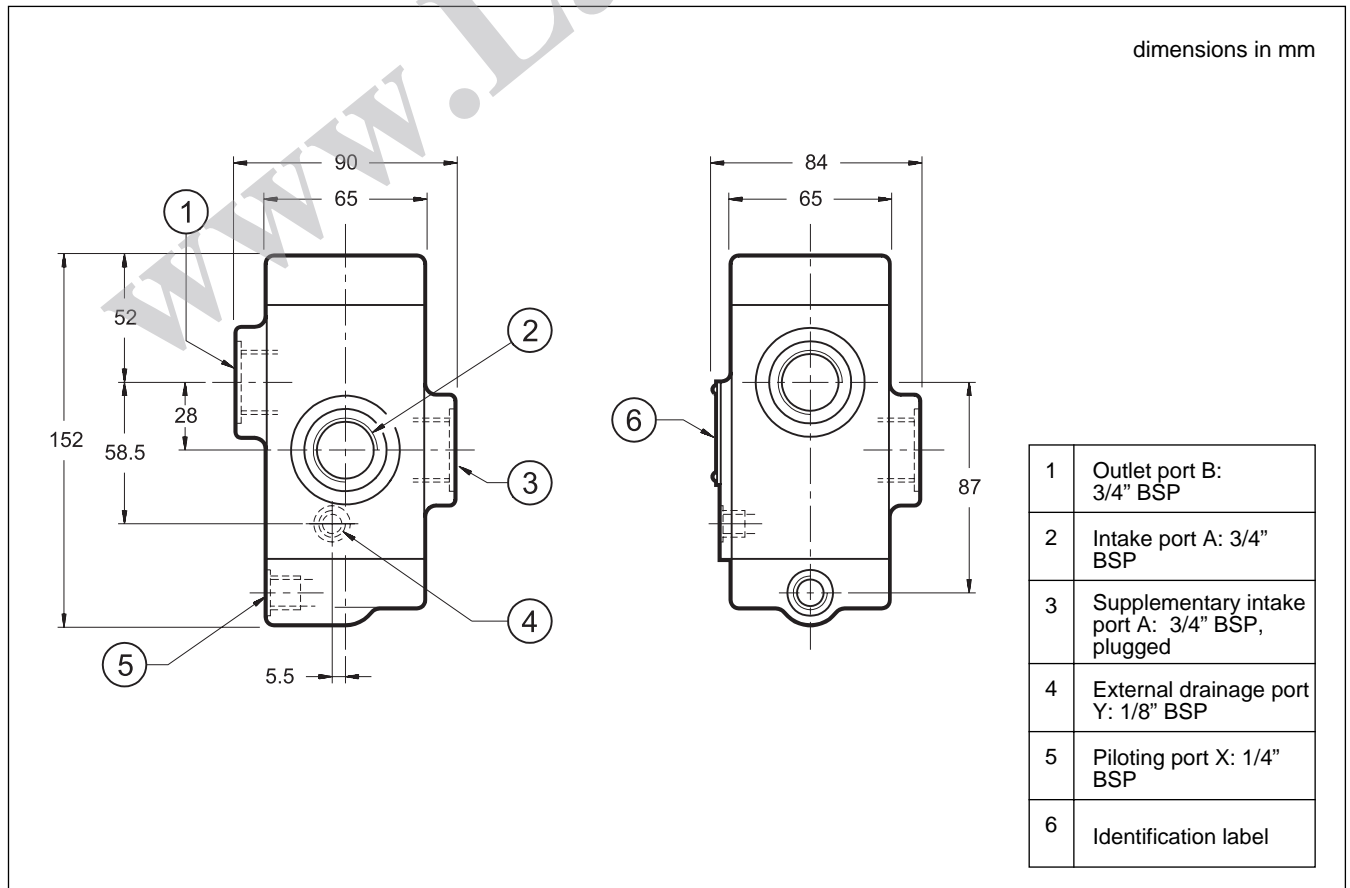



# VP\*-W\*-MU

## SERIES 12

### 6 - USE

The VP\*-W\*-MU check valves with hydraulic release are used in circuits where the position of the actuators must be maintained even in the absence of hydraulic power.

They are available in two versions with the following characteristics:

**VP\*-W\*-MU** The VP\*-W\*-MU valves are check valves with hydraulic release that incorporate the functions of a normal one-way check valve with the possibility to release the poppet by means of external piloting, thus allowing flow of the oil also in the opposite direction of the free flow, from B to A. The valve poppet, a cone on edge seal type, is kept closed by a spring with fixed setting during rest conditions. When pilot pressure is sent to port X, the release piston is activated and opens the main poppet, thus allowing the reverse flow. These valves have hydraulic isolation of the front face of the release piston from chamber A of the valve, by external drainage Y. This solution eliminates problems which can occur if, during the release phase of the valve, pressure builds up in chamber A near to or greater than the piloting pressure X, causing a backward movement of the piston and thus unwanted closure of the valve.

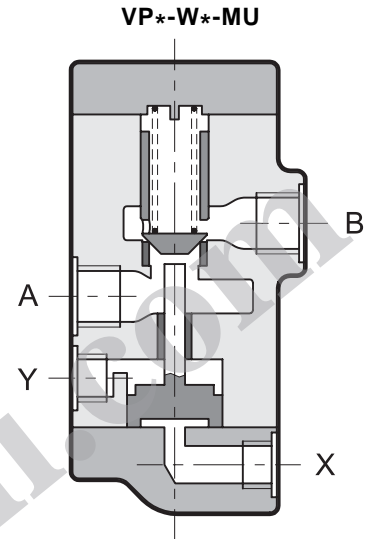

**VP\*-W\*/P-MU** The VP\*-W\*/P-MU valves are check valves with hydraulic release that, in addition to the characteristics of the preceding version, are equipped with a decompression device. They are recommended when operating with high working pressures or with high loads that act as pressure multipliers. The circuit (chamber B) is decompressed prior to complete opening of the valve during the release phase. This prevents pressure shocks in the circuit and because of the high ratio existing between the areas of the control piston and the decompression device, release can occur even at a low piloting pressure. Pilot pressure to port X operates the release piston which first opens the pre-opening poppet, causing decompression of the sealed chamber, it then opens the main poppet, allowing free flow from B to A.

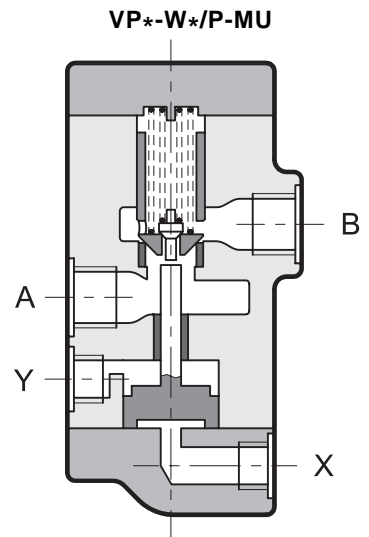

**DIPLOMATIC OLEODINAMICA SpA**  
20025 LEGNANO (MI) - P.le Bozzi, 1 / Via Edison  
Tel. 0331/472111 - Fax 0331/548328